

# The Ambassador Crown™

provides features that other peak style houses do not achieve:

- Built-in condensation removal channels
- Roll formed structure for superior strength
- Easy expansion capabilities
- Aluminum vents for roof, sides and gables
- Aluminum finish trim on corners and gables
- Loading capabilities to meet your needs and codes
- Glazing in glass, corrugated polycarbonate, acrylic or twin wall polycarbonate
- Large walk-in gutters

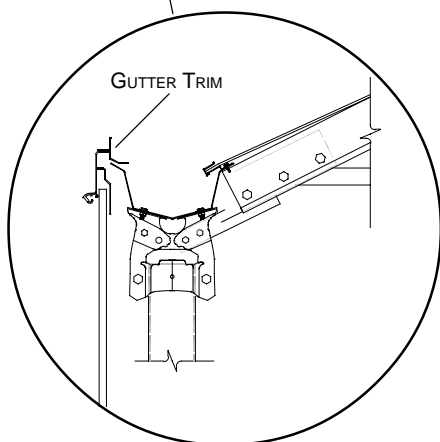
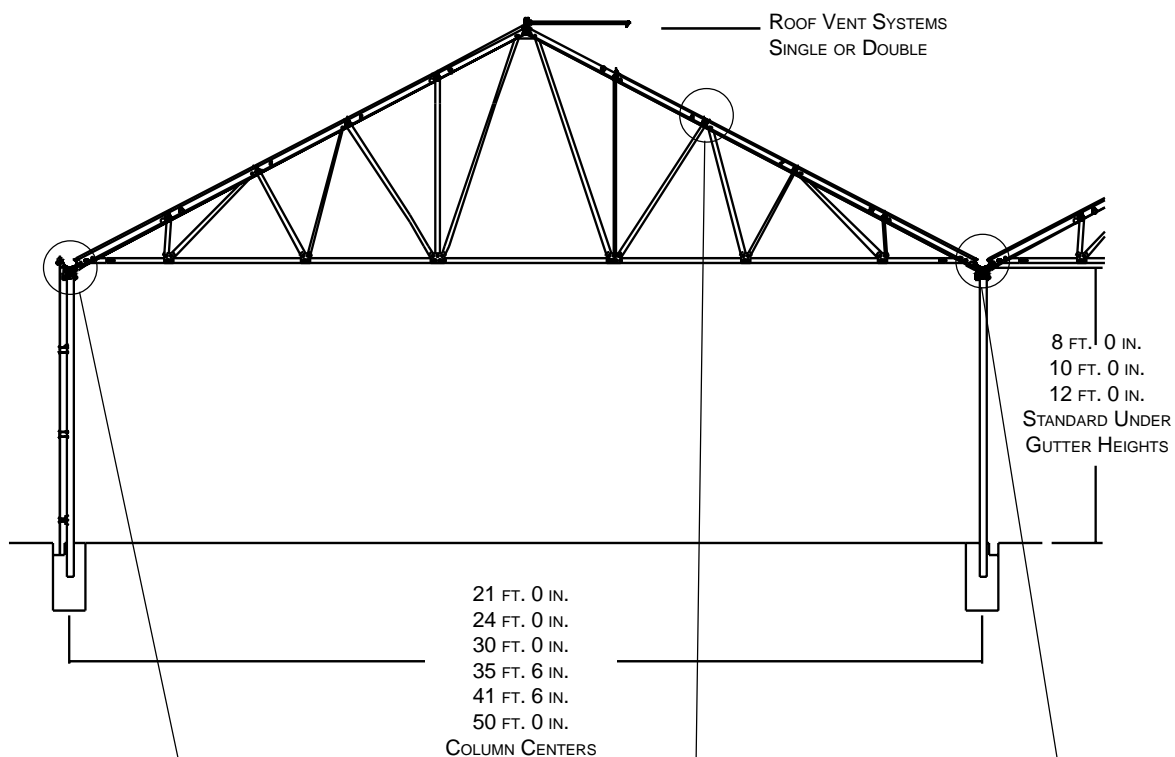

## Gutter Trim

Gutter trim extrusion gives a finished look and receives the sidewall glazing panels.

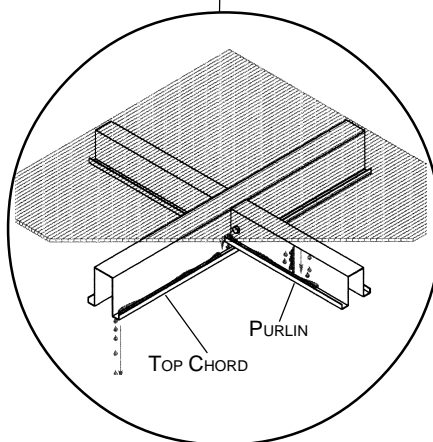

## Condensation Removal

Purlins and top chords carry off condensation in built-in channels to the gutter line.

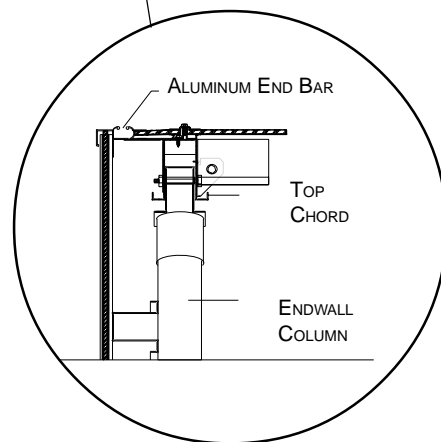

## End Bar Trim

Trims the end of the roof glazing as well as the endwall.

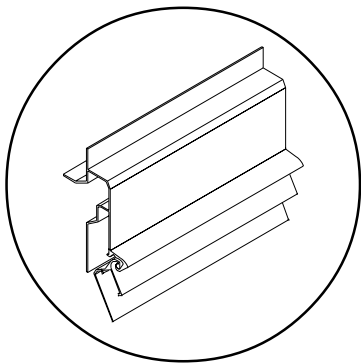
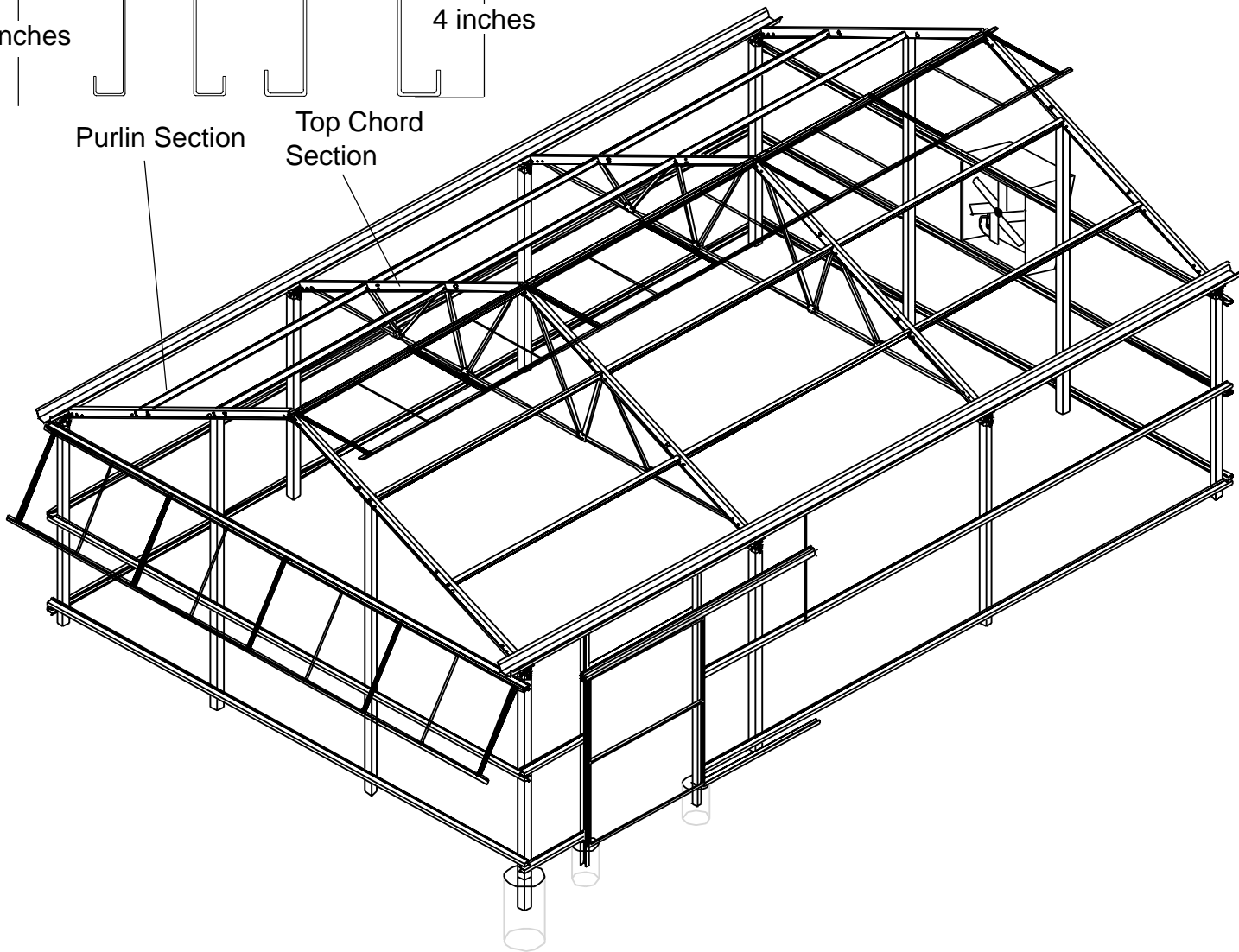
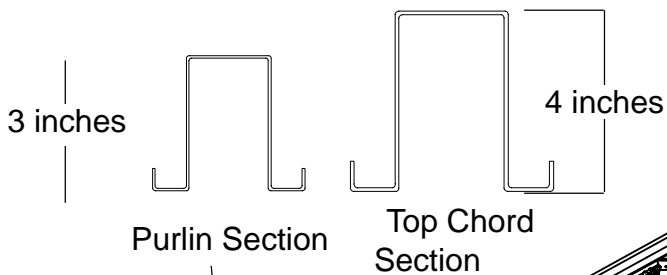

**Sidewall & Endwall Vents**

Continuous heavy duty extruded aluminum, designed for various glazing with a special lock-in hinge.

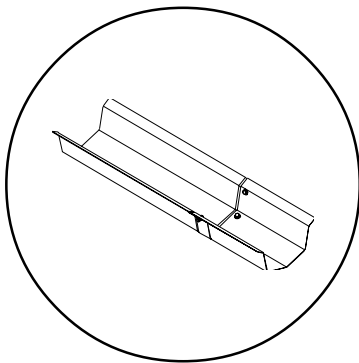

**Galvanized Steel Gutters**

Downsets provide easy installation and help prevent leakage.

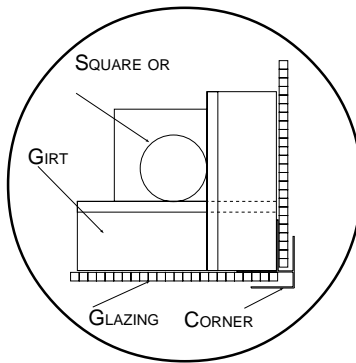

**Aluminum Corner Trim**

Trims the corner for a finished look and receives the glazing.

**United Greenhouse Systems, Inc.**

offers a complete line of accessories including: Exhaust Fans, Cooling Systems, Heating Systems, Shade & Heat Retention Curtains, Benches, Doors and Control Systems.