

# The Diplomat 30™

provides a roll-formed steel structure that gives maximum strength per dollar:

- Built-in condensation removal channels
- Roll formed structure for superior strength
- Easy expansion capabilities
- Gothic Arch shape promotes faster run off of rain and condensation
- Glazing in double-poly or twinwall polycarbonate
- Aluminum finish trim available for corners and gables
- Bolt together construction

## Additional Features and Options:

- High sidewall - 48 inch for wall-to-wall production, including benches.
- 13 ga column leg
- Optional steel endwall frame
- Optional glazing in corrugated polycarbonate or twinwall polycarbonate for endwalls.
- Optional rigid glazed roof vent.
- Optional 4 foot x 24 foot cooling pad system

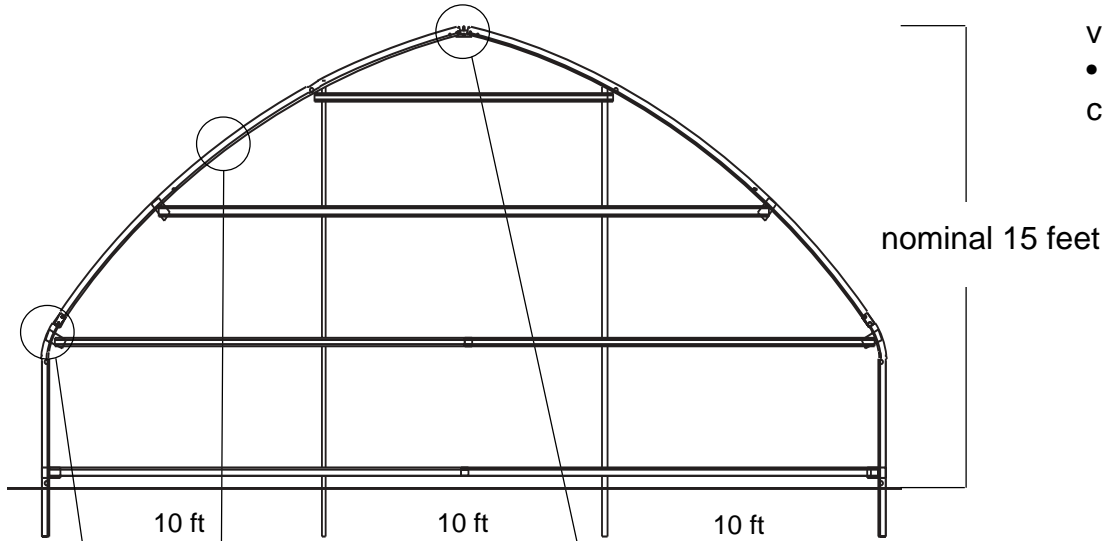

Optional Steel Endwall Framing is available

## United Greenhouse Systems, Inc.

offers a complete line of accessories including: Exhaust Fans, Cooling Systems, Roll-up side-walls, Benches, Doors and Control Systems.

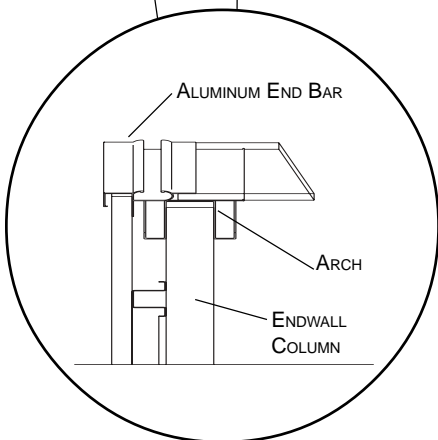

**End Bar Trim**  
(OPTIONAL)

Trims the end of the roof glazing as well as the endwall.

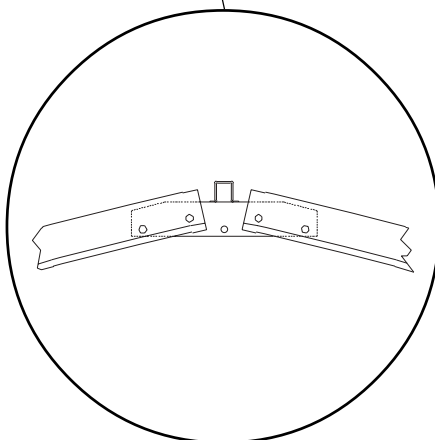

**Splice Chevron**  
Joins two arch halves

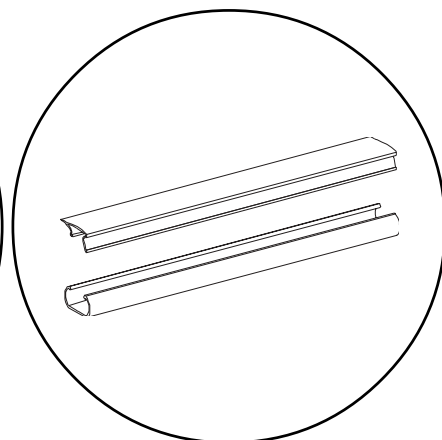

**Aluminum Poly Clasp**  
(OPTIONAL)

Extruded base and cap  
No special tools are required.

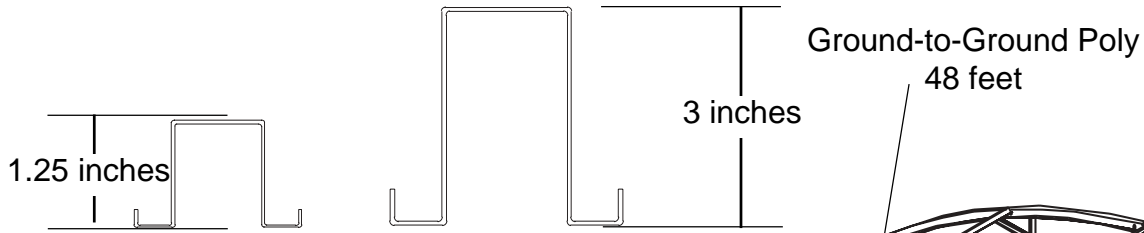

Purlin/Girt  
Section 18 ga.

Top Chord Section  
18 ga

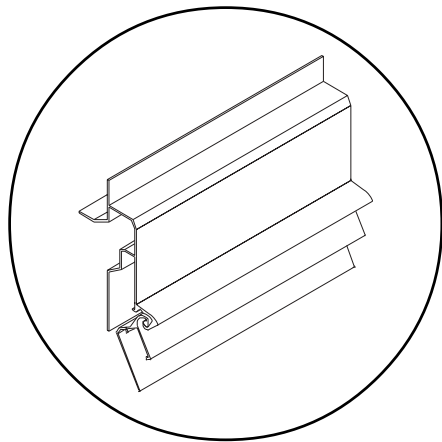
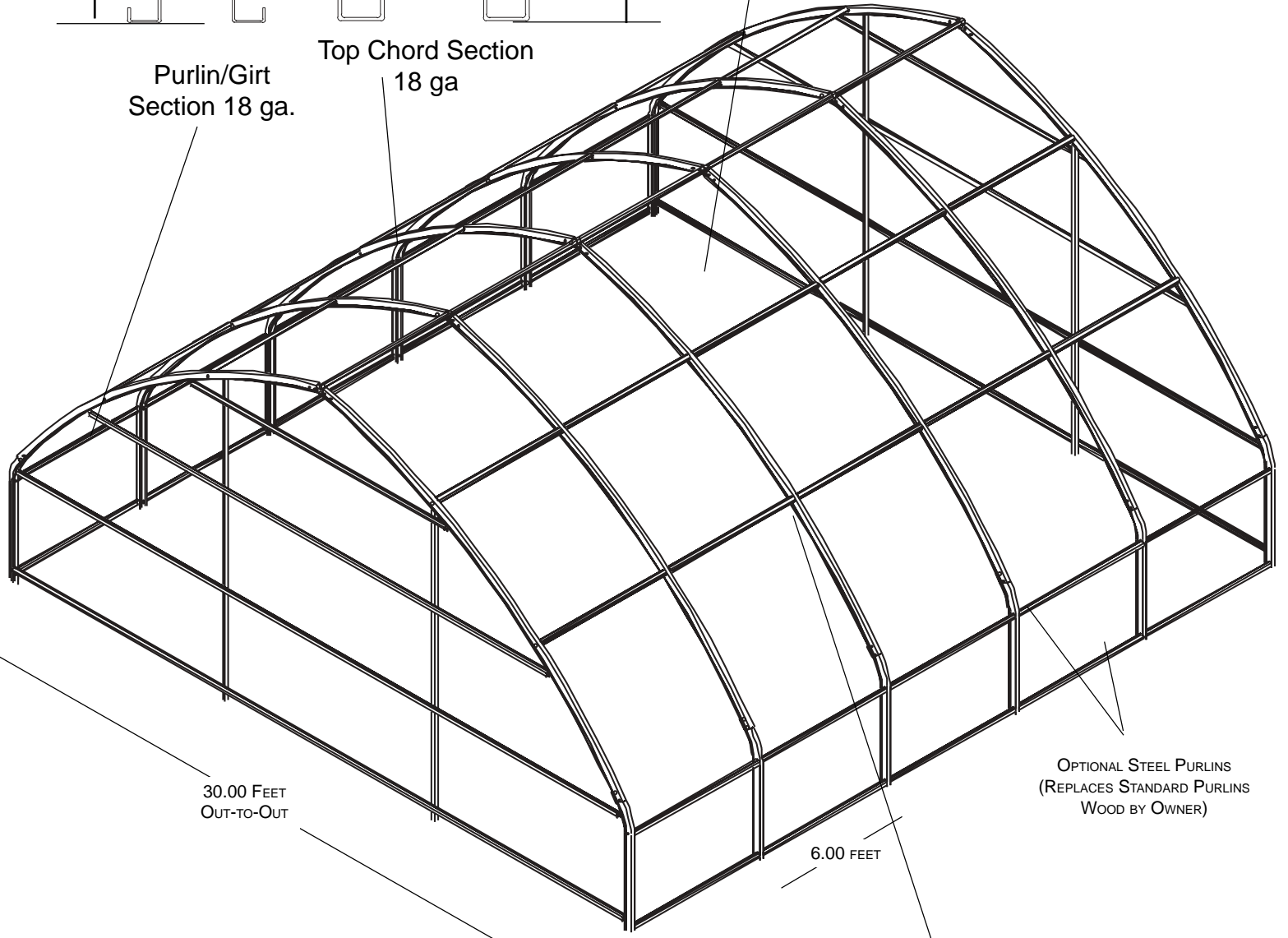

**Sidewall & Endwall Vents**  
(OPTIONAL)  
Continuous heavy duty extruded aluminum with a special hinge.

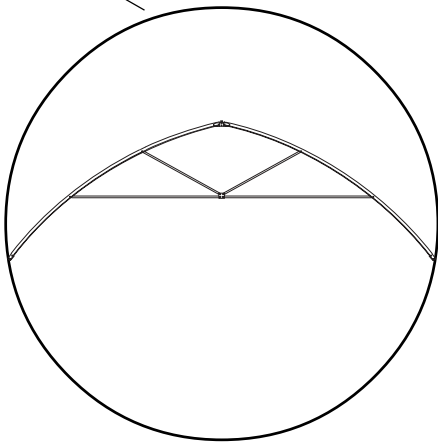

**Structural Upgrades**  
(OPTIONAL)  
For intermediate trusses, bottom chord and two struts.

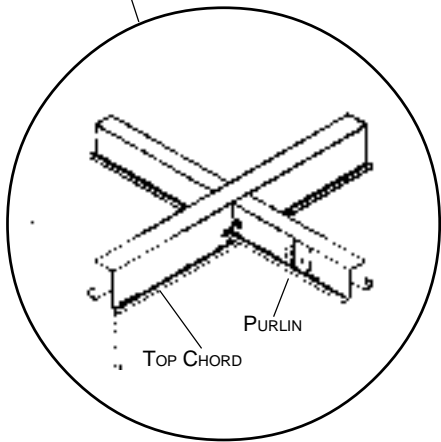

**Condensation Removal**  
Purlins and top chords carry off condensation in built-in channels to the gutter line.